



Phone: (403) 851 1900
E-mail: info@flexreeltrailers.com

FR-300 Series self-loading reel trailer with unspooler



- Safely handles pipe, wire, cable and conduit reels**
- Self-loads wood or steel reels**
- Ideal for stringing or re-spooling continuous lengths**
- Easy to operate**



Phone: (403) 851 1900
E-mail: info@flexreeltrailers.com

FR-300 Series self-loading reel trailer with unspooler



- Powered unspooler controls reel speed to prevent product damage**
- Manual includes detailed instructions for safe operation**
- Transports reels on public highways or rough off-road terrain**

FR-300 Series self-loading reel trailer with unspooler

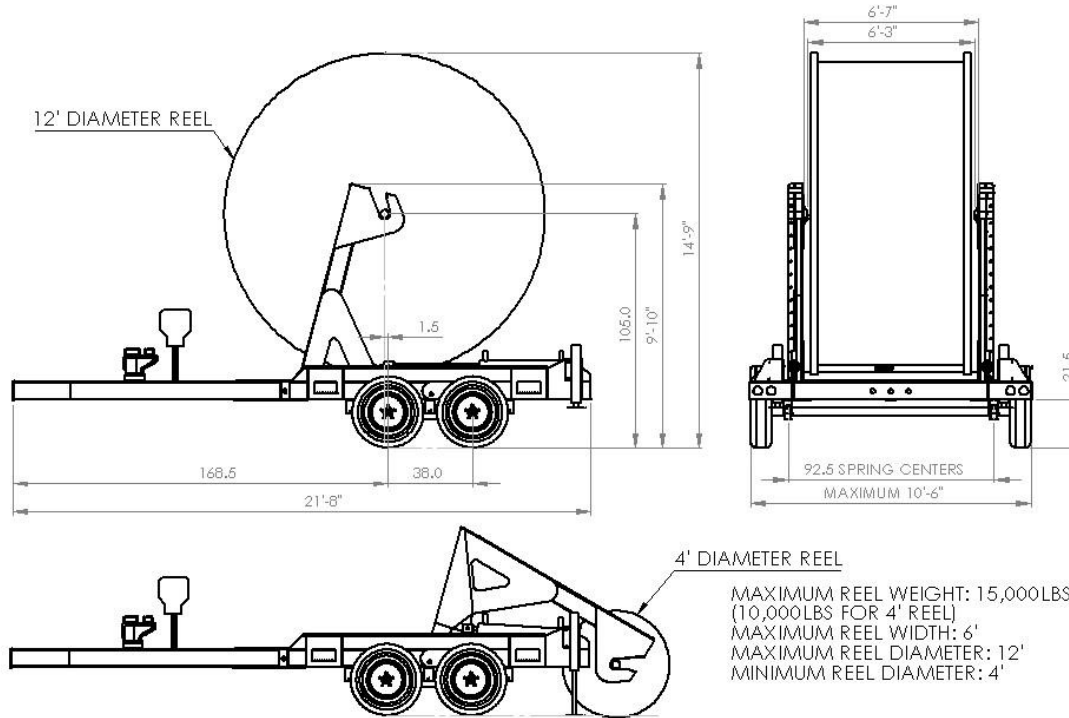

- Durable and proven design**
- Reliable and low maintenance**
- Powered by Honda hydraulic power unit with electric start**
- Tandem axle running gear with leaf spring suspension**



Phone: (403) 851 1900
E-mail: info@flexreeltrailers.com

Specifications

FR-300		
Parameter	Metric	Imperial
Reel Dimensions		
Maximum Reel Diameter	3.66 m	12 ft
Minimum Reel Diameter	1.22m	4 ft
Maximum Reel Width	1.83 m	6 ft
Maximum Reel Weight	6,800 kg	15,000 lbs
Weights		
Trailer	2,720 Kg	6,000 lbs
Trailer with unspooler	2,900 kg	6400 lbs
Gross Vehicle Weight Rating	9,525 kg	21,000 lbs
Gross Axle Weight Rating (per axle)	4,080 kg	9,000 lbs
Gross Axle Weight Rating (total)	8,160 kg	18,000 lbs
Width dimensions		
Trailer	3.20 m	10 ft – 6 in
With unspooler	3.20 m	10 ft – 6 in
With respooler	n/a	n/a
With brake	n/a	n/a
Height dimensions		
Trailer without reel	3.05 m	10 ft
Maximum with 4' reel	3.35 m	11 ft
Maximum with 12' reel	4.57 m	15ft
Maximum with 14' reel	n/a	n/a
Length dimension	6.40 m	21 ft
Maximum Transport Speed		
Without reel	100 km/hr	60 mph
With reel	80 km/hr	50 mph